

Aquair 100

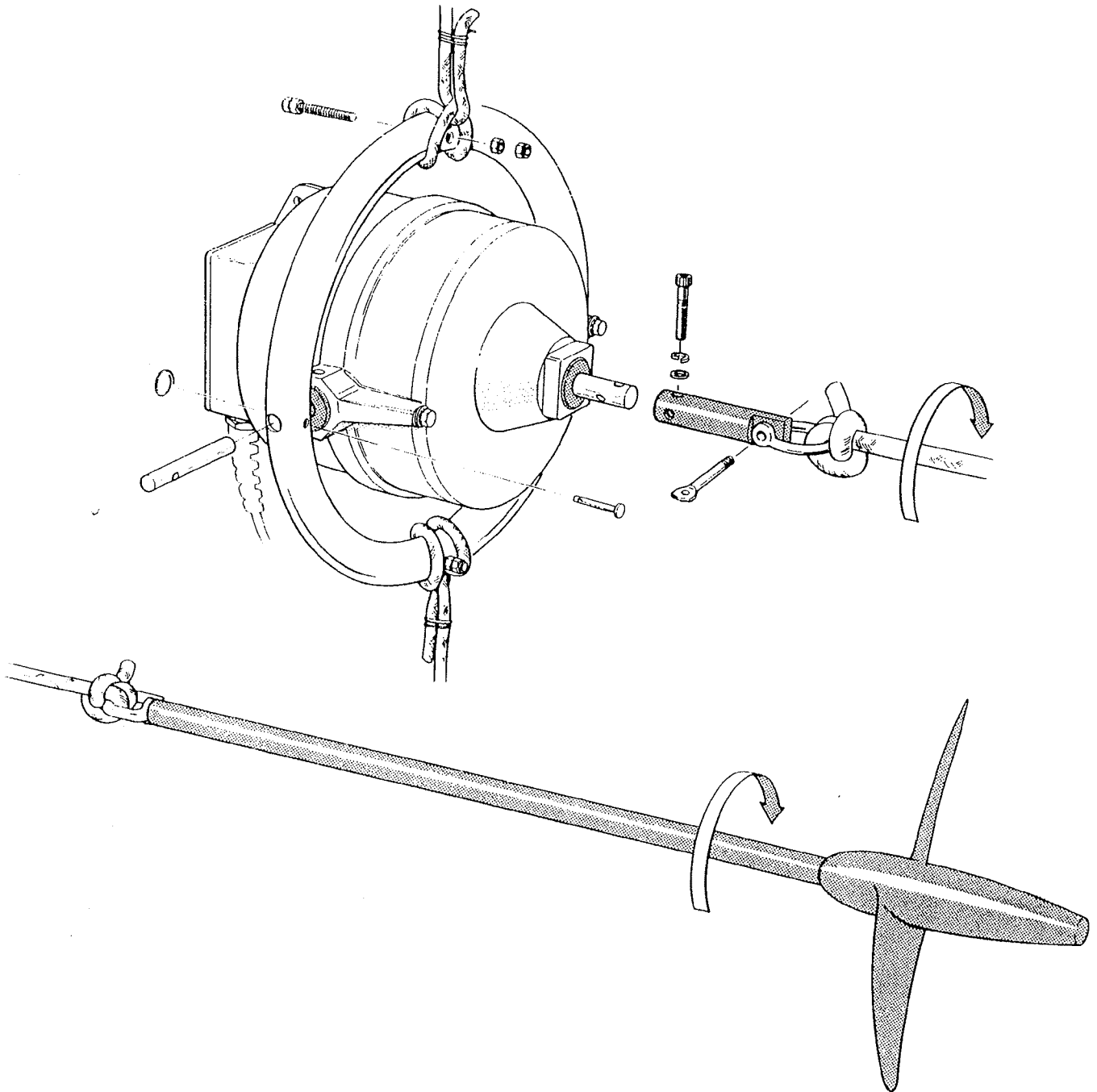

Owners Manual
Installation & Maintenance

AQUAIR 100 MANUAL

INDEX

	PAGE
SYSTEM DESCRIPTION	2
Introduction	2
The Generator	2
Water Mode	2
Wind Mode	3
INSTALLATION	4
Water Mode	4
Wind Mode	6
ELECTRICAL INSTALLATION	11
Wiring	11
Charge Control Regulators	12
OPERATION & PERFORMANCE	14
Water Mode	14
Wind Mode	15
MAINTENANCE	16
Cut-away Drawing	16
List of Parts	16
Inspection	16
Major Disassembly	17
Spares List	19
DIMENSIONS	19

WARRANTY

The Aquair 100 is warranted for one year from the date of purchase. Any faulty part will be replaced free of charge and any faulty workmanship will be rectified free of charge upon prepaid return of a unit to Ampair or any authorised agents. The unit will then be returned to the customer free of charge.

This guarantee does not cover mishandling, accidental damage or faulty installation. Nor can Ampair or its authorised agents be liable for any consequential damage.

Ampair will, nevertheless, go to considerable lengths to ensure customer satisfaction and fully appreciate the problems of those in far away places.

AQUAIR 100 SYSTEM DESCRIPTION

INTRODUCTION

The Aquair 100 is a dual capability generator which can be either water or wind driven. It is capable of supplying up to 100 Watts of electrical power at either 12 or 24 Volts for charging batteries.

THE GENERATOR

This unit consists of a two part cast aluminium body, the two parts sealed by an "O" ring. Two six-pole magnetic rotors run with their poles in line on a stainless steel shaft. The shaft runs in two sealed grease packed ball bearings with the front bearing protected by a shaft seal. Two six-pole stators are arranged with their poles staggered at 30 degrees to minimise "cogging" or break-out torque and so allow easy starting. The unit is assembled with one stator in the main body casting and the other in the nose piece. During assembly these are precisely aligned on the test bench to give optimum performance. A small timing mark is made at the junction of the case halves to allow accurate re-assembly. The A C output is rectified by two bridge rectifiers, one per stator. The D C output of the two rectifiers is paralleled and passes to the output cable. The output is isolated from the case.

WATER MODE

In water mode the generator body is mounted in a stainless steel gimbal ring. The body pivots on two stainless steel pins running in acetal bushes. The pivot pins are retained in the ring by two clevis pins.

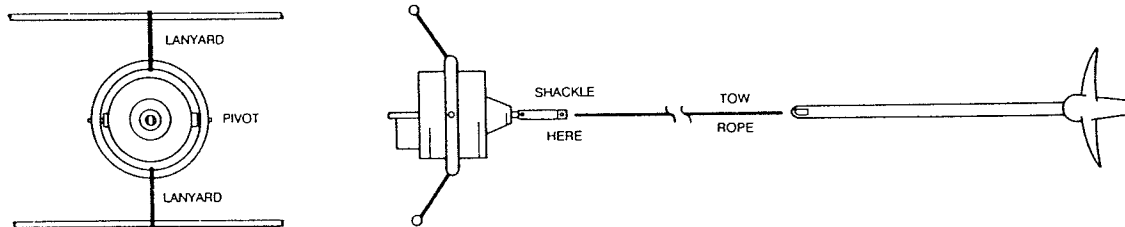

Figure 1. Water Mode.

The Gimbal Ring. The gimbal ring is attached to the boat's stern pulpit, or other convenient horizontal structure, by two lanyards, one at the top the other at the bottom. These lanyards must be located, by the fixings provided on the gimbal ring, at 90 degrees to the pivot axis. This arrangement gives freedom to move on a horizontal axis due to the gimbal ring pivots and on a vertical axis due to the lanyards. A permanent deck mount option is available (see Fig, 6)

The Towed Turbine. This consists of an aluminium propeller mounted on a stainless steel shaft with a "D" ring rope attachment. This is attached to the generator by 30 metres (100 ft.) of 12mm braid on braid polyester rope via a bow shackle and acetal shaft connector. The shackle and shaft connector are attached to the generator shaft by an M6 x 30mm stainless steel capscrew with shakeproof washer. The shaft connector is made to break at a load of approx. 300kg (700lb) to safeguard the generator in the event of the towed turbine being caught on rocks, coral etc. For boats consistently exceeding 7 knots, a coarse pitch towed turbine is available.

WIND MODE

Hoist in the rigging (fig. 2)

In wind driven mode the generator is removed from its gimbal ring and fitted with two swivel tubes containing PTFE bearings in stainless steel swivels. The tubes are located in the body in the positions previously occupied by the gimbal pivot bushes. The unit is then slung aloft by a halyard or other suitable hoist attached to the upper swivel "D" ring. The lower swivel is then tied down by, ideally, three ropes on a triangular plan to provide a stable arrangement.

Pole mount (fig.3)

Alternatively, the generator can be pole mounted using a pivot and bush arrangement.

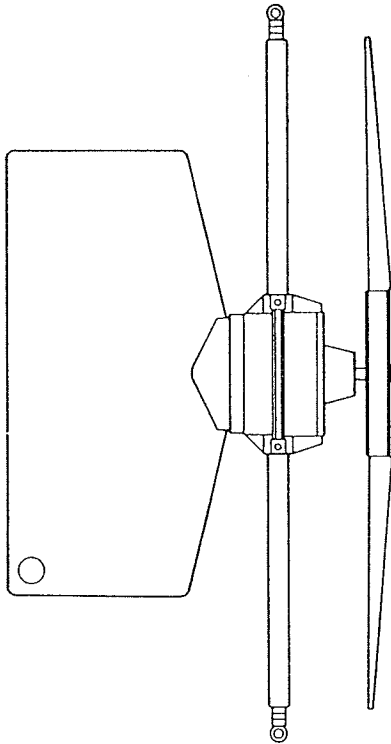

Figure 2. Wind Mode Hoist in Rigging

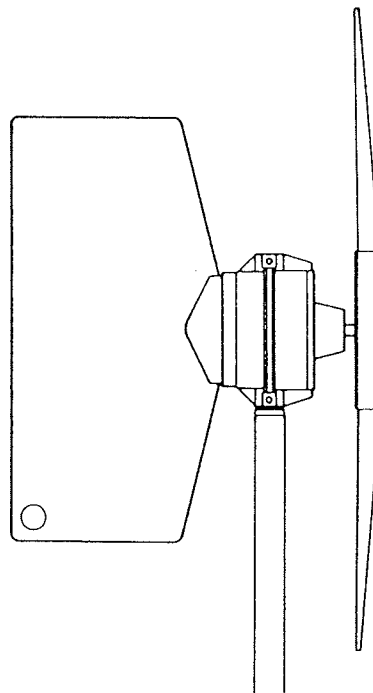

Figure 3. Wind Mode Pole Mount

The Tail Vane. An aluminium alloy tail vane is attached to the rear of the generator body by three M6 x 16mm stainless steel screws with shakeproof washers and nuts. The vane is provided with a grab hole at its lower rear corner to facilitate turning the unit cross-wind to stop the wind turbine rotating when required.

The Wind Turbine. This consists of six cambered and twisted compression moulded blades of glass-fibre reinforced polypropylene. This material has exceptional fatigue resistance and retains its durability down to sub-zero temperatures. The blades are factory selected for balance to less than 1g and are delivered as colour coded matched pairs. The blades are retained by M8 x 40mm stainless steel bolts with shakeproof washers and nuts, two of each per blade, in a hub assembly consisting of two aluminium alloy plates mounted on a turned and anodised aluminium alloy hub centre piece. The hub centre is bolted to the plates by three M6 x 40mm stainless steel screws with shakeproof washers and nuts. The hub is fitted to the generator shaft by two M6 x 30 stainless steel cap screws with shakeproof washers. Three Bungs in the front hub plate allow access to the shaft screws, one bung being notched to clear the front cap screw head.

INSTALLATION

WATER MODE INSTALLATION

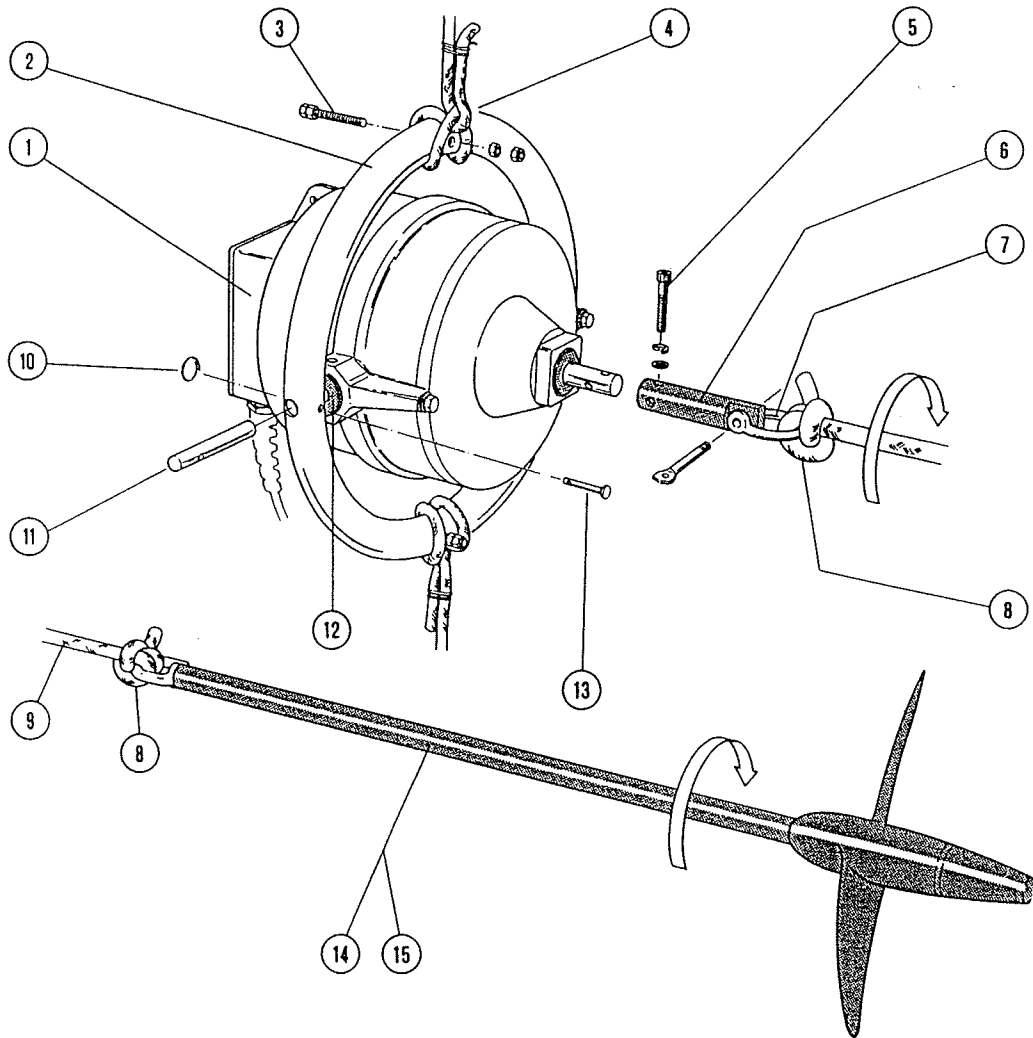

Figure 4. Aquair 100 Towed Turbine *NOTE Safety line not shown*

KEY.	1. Generator Assembly	6. Shaft Connector	11. Pivot Pin (2)
	2. Gimbal Ring	7. Bow Shackle	12. Pivot Bush (2)
	3. Location Fasteners (2)	8. Fisherman's Bend	13. Clevis Pin (2)
	4. Clove Hitch	9. Tow Rope	14. Standard Pitch Turbine
	5. Shaft Fasteners	10. Lock Ring (2)	15. Coarse Pitch Turbine (grooved)

Pre Installation Check. Check that a complete and undamaged set of parts has been received.

The Aquair 100 12V or 24V water generator set consists of the generator body, complete with shaft connector and shackle, mounted by means of acetal bearings with stainless, steel pivot pins, clevis pins and locking ring in a stainless steel gimbal ring. One standard pitch towed turbine and 30 metres (100 ft.) of 12mm braid on braid rope.

Conversion. If converting from wind powered operation proceed as follows:-

Assemble gimbal ring to generator applying silicone grease to the acetal bushes to prevent them seizing in the body casting. Insert the pivot pins, clevis pins and locking rings.

WATER MODE INSTALLATION

Fitting to the Stern. attach rope lanyards to gibal ring top and bottom using the fixings as a means of positive location (see figure 5) It is suggested that a clove hitch knot is used passing either side of the fixing. The lanyards should be as short as possible consistent with freedom to twist thus allowing full gimbaling, secure the free ends in case of slip. This will ensure self alignment of the generator shaft with the water turbine tow-rope. If the stern pulpit, or other structure used as a mounting, is not robust and absolutely rigid, it is recommended that it be cunter-braced to some strong point on the boat in order to prevent damage should the tow rope and water turbine become snagged. The generator and gibal ring are designed to withstand an ultimate load of 450kg (1000lb).

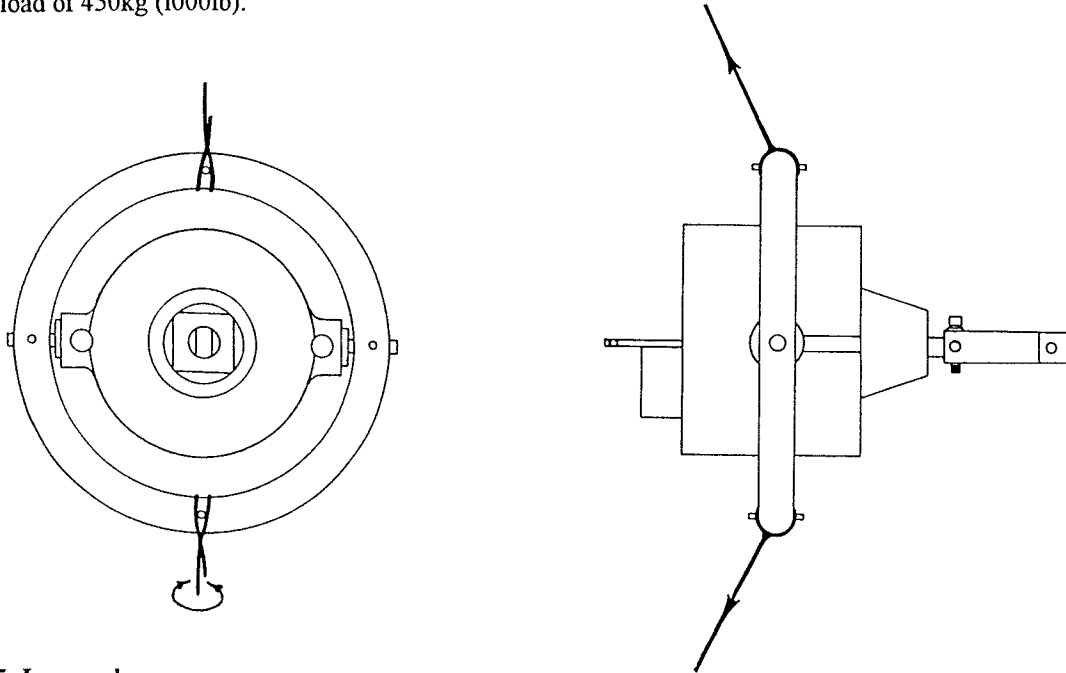

Figure 5. Lanyards.

Tow Turbine. Attach the acetal shaft connector and shackle to the Aquair shaft with the M6 cap screw and shakeproof washer provided. Attach tow rope to shackle and tow turbine, we suggest a fisherman's bend knot with the free ends whipped to the rope.

Permanent Deck mount Option. This is available for those wishing to make a fixed installation on the Aquair. The unit consists of a welded stainless steel frame in which the Aquair is mounted. This provides a very neat arrangement where the existing gimbal ring provides the horizontal axis and the Deck Mount the vertical axis. This allows the application of the Aquair where no stern rail or structure is present such as on a catamaran. The unit is simply bolted to the deck.

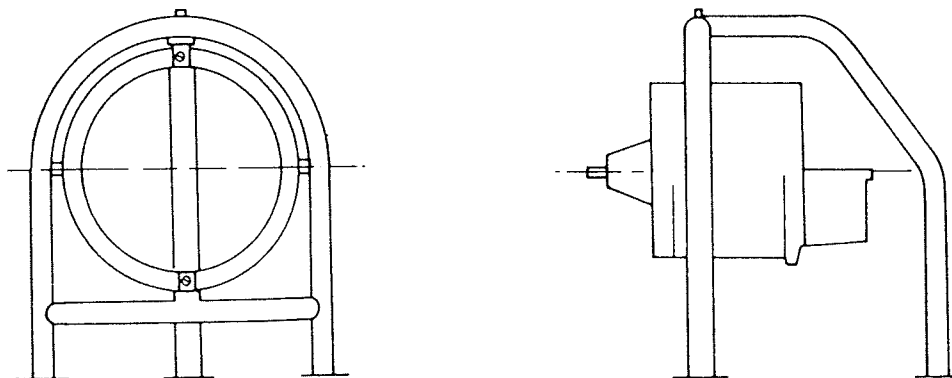

Figure 6. Stern Deck mount.

WIND MODE INSTALLATION - Hoist In Rigging. (HIR)

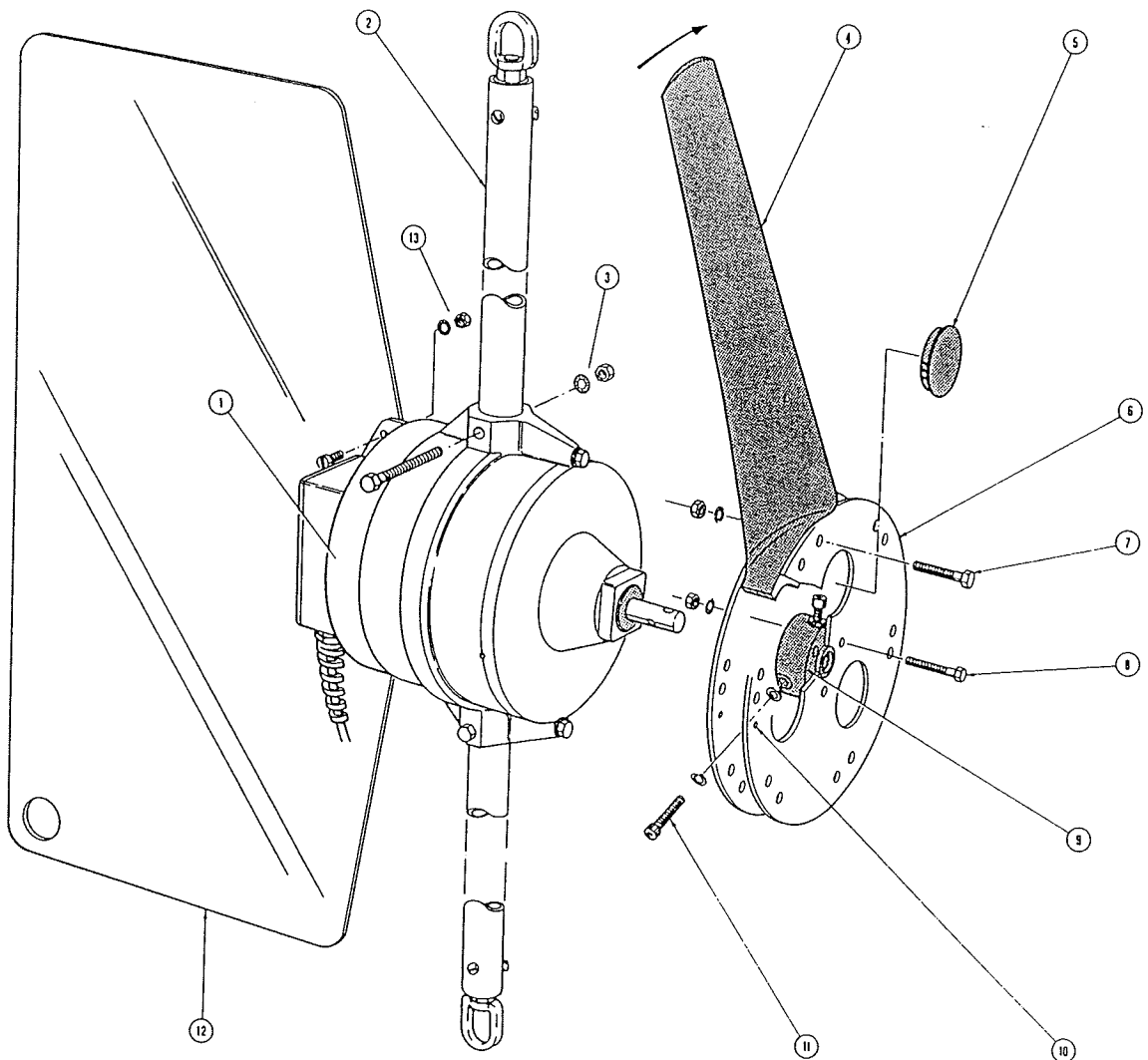

Figure 7. Aquair Wind kit Hoist in Rigging.

KEY.	1. Generator Assembly	6. Hub Plate (2)	11. Shaft Fasteners
	2. Swivel Tube	7. Blade Fasteners (12)	12. Tail Vane
	3. Swivel Tube Fasteners	8. Hub Fasteners (3)	13. Tail Vane Fasteners
	4. Blade (6)	9. Hub Centre	
	5. Bung (3)	10. Guide Hole	

Pre. Installation Check. Check that a complete and undamaged set of parts has been received. The Aquair Wind kit H I R set contains six wind turbine blades packed as three colour-coded balanced pairs. One hub assembly complete with plastic bungs. Two swivel poles. One tail vane. The hardware kits contain:-

Kit 1. Wind blade fixings

12 M8 x 40mm hex bolts
12 M8 nuts
12 M8 shakeproof washers

Kit 2. H I R fixings

2 M8 x 50mm hex bolts
2 M8 nuts
2 M8 shakeproof washers
2 M6 x .30mm cap screws
2 M6 shakeproof washers

1 5mm hexagon wrench (Allen key)
3 M6 x 16mm screws
3 M6 shakeproof washers
3 M6 plain washers
3 M6 nuts

Conversion. Find a suitable location for suspending the Aquair 100. Remove the locking rings from the clevis pins and remove clevis pins, pivot pins and acetal bushes. If they are stiff to remove, the bushes may be gently prised out by introducing a small lever through the holes in the sides of the pivot housings and engaging the groove in the bush. If completely corroded in, then fill centre hole with grease and use pivot pin as a piston to knock into hole and force bush out. Remove the acetal shaft connector.

Swivel Poles. Attach the swivel poles to the generator "ears" using the M8 x 50mm bolts, shakeproof washers and nuts provided. Do not fit the turbine and tail vane.

Suspension. Partially hoist the Aquair 100 to enable assembly of the tail vane and wind turbine. To minimise sway, connect the lower swivel to the deck by three guys at approx. 120 degrees to each other, viewed from above. Do not apply excessive tension since this will result in rapid wear of the PTFE swivel bearings.

Cable. Secure the output wire to the lower swivel pole and to one of the lower guys.

Wind vane. Using the three M6 x 16mm screws, washers and nuts provided, fit the vane to the rear of the Aquair body.

Turbine assembly. First, check that the hub plates are correctly fitted to the hub-centre. Each plate has a small hole near one of the 12 blade fixing holes, these should line up. The blades are supplied as colour coded pairs (see the colour code on the blade base). These pairs should be assembled finger tight to the hub, in opposite positions, using the M8 x 40mm bolts shakeproof washers and nuts provided. The bolts are a deliberately tight fit but may be screwed in using a socket spanner.

Note. The concave (hollow) side of the blade faces the wind.

Tighten the blade bolts working on opposite pairs in sequence. It is a good idea to re-tighten fixings after a few hours use since some compression of the materials may have taken place.

Fitting the wind turbine. Remove the plastic bungs from the hub plate to gain access to the hub-centre to shaft fixing holes. Carefully align the wind turbine hub and gently slide on to the shaft. Using the M6 x 30mm cap screws shakeproof washers and hexagon wrench provided, fit the turbine to the shaft. Tighten fully.

DANGER WARNING

The wind turbine blades are easily capable of causing grave personal injury, even in light wind, and should be treated with the same respect as an aircraft propeller.

IT IS ESSENTIAL THAT THE AQUAIR BE HOISTED WELL ABOVE HEAD HEIGHT

Do not let go of the blades until all personnel are clear. Rotate the Aquair to face the wind and step back before letting go.

CAUTION: LEAVE A LOOP WHERE THE CABLE PASSES THE SWIVEL

This will allow the unit to rotate in the wind. Do not make the loop so big as to risk fouling the blades.

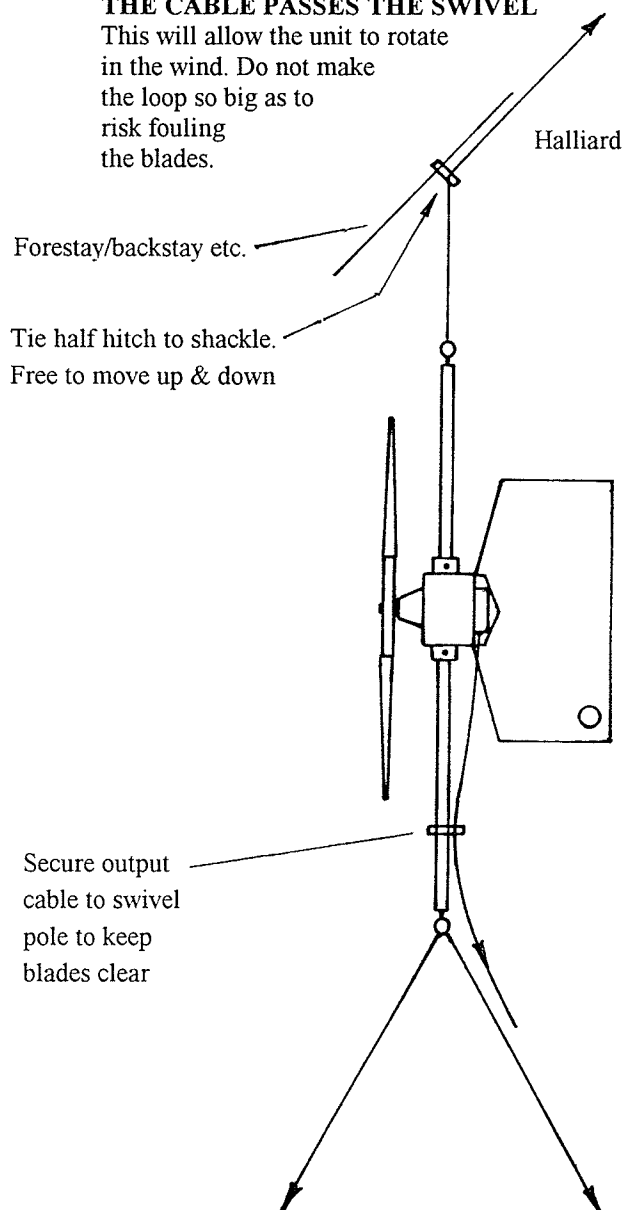

Figure 8. Aquair Hoist In Rigging mounting

WIND MODE INSTALLATION - Pole Mount. (PM)

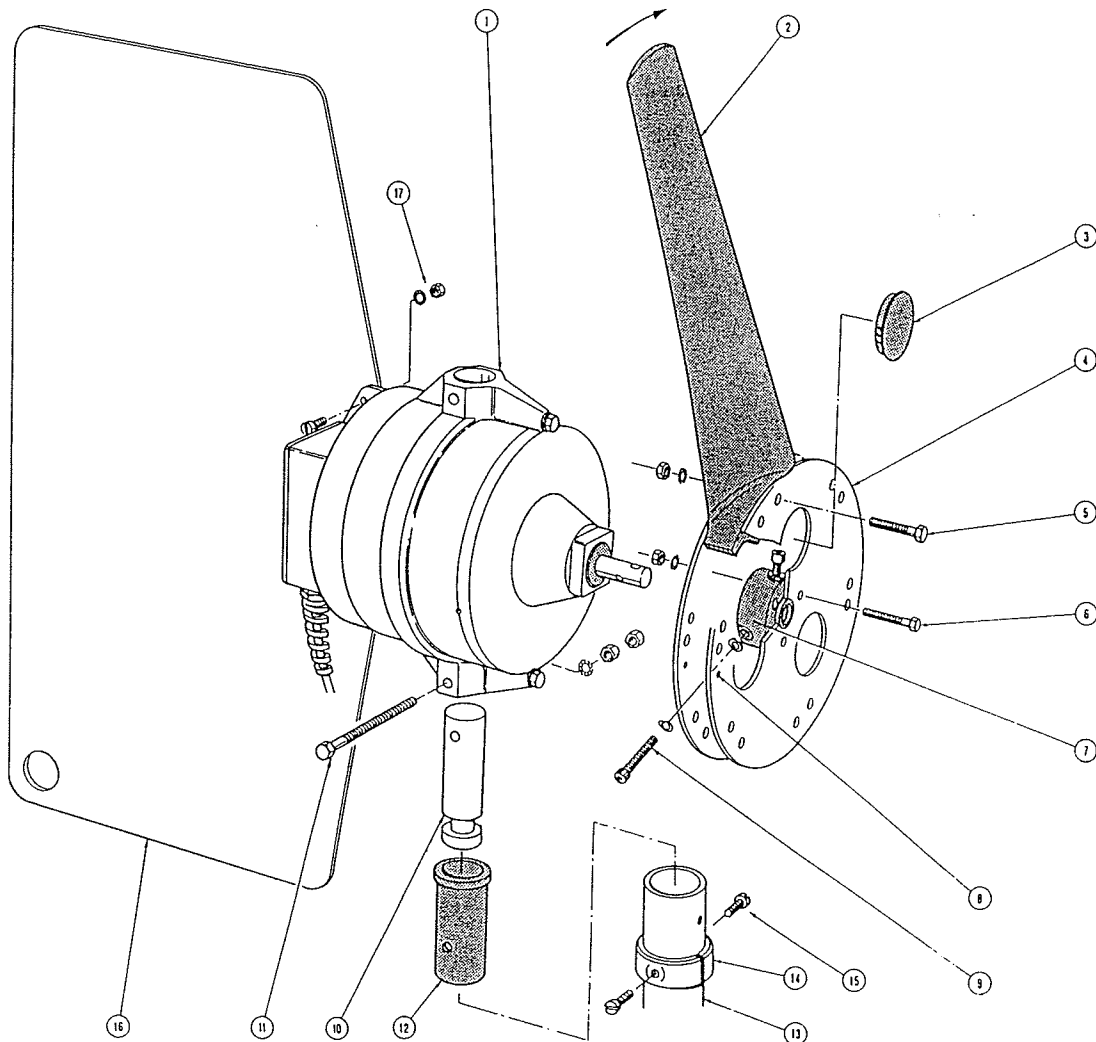

Figure 9. Aquair Wind kit Pole Mount.

KEY	1. Generator Assembly	7. Hub Centre	13. Mounting Pole
	2. Blade (6)	8. Guide Hole	14. Pole Collar
	3. Bung (3)	9. Turbine Fasteners (2)	15. Collar Fasteners (2)
	4. Hub Plate (2)	10. Pivot Shaft	16. Tail Vane
	5. Blade Fasteners (12)	11. Pivot Fasteners (1)	17. Tail Vane Fasteners (3)
	6. Hub Fasteners (3)	12. Pivot Bush	

Pre. Installation Check. Check that a complete and undamaged set of parts has been received.

The Aquair Wind kit P M set contains six wind turbine blades packed as three colour-coded balanced pairs. One hub assembly complete with plastic bungs. One 800mm mounting pole. One tail vane. One PM pivot set comprising an alluminium alloy pivot, an acetal bush and an aluminium alloy collar. The hardware kits contain:-

Kit 1. Windblade fixings

12 M8 x 40mm hex bolts
12 M8 nuts
12 M8 shakeproof washers

Kit 2. PM fixings

1 M8 x 50mm hex bolt
1 M8 nut
1 M8 shakeproof washer
2 M6 x 30mm cap screws
2 M6 shakeproof washers
1 5mm hexagon wrench (Allen key)

3 M6 x 16mm screws
3 M6 shakeproof washers
3 M6 plain washers
3 M6 nuts
2 M6 x 20mm screws
2 M6 shakeproof washers

This arrangement differs from the Hoist in rigging method as follows:-

Pole mount adapter. Having found a suitable position in which to mount the pole, insert the acetal bush in the top of the pole so that the holes in the bush line up with those in the pole. Pass the anodised collar over the pole and bush, then, whilst holding the collar so the threaded holes line up with those in the pole, insert the two M6 x 20mm screws with shakeproof washers just enough to enter the thickness of the bush. Do not yet screw fully in.

Pivot. Insert the PM pivot in one "ear" of the Aquair 100 body so the cable exit gland is downwards and, using the M8 x 50mm bolt, shakeproof washer and nut, tighten firmly.

Pole mounting. Place the Aquair 100 on the pole, gently guiding the pivot down into the bush on the top of the pole. Fully tighten the two M6 x 20mm screws in the anodised collar. The threads now protrude into the groove in the pivot effectively trapping it in place.

Cable. Secure the cable in such a way that the Aquair can turn at least 360 degrees in each direction.

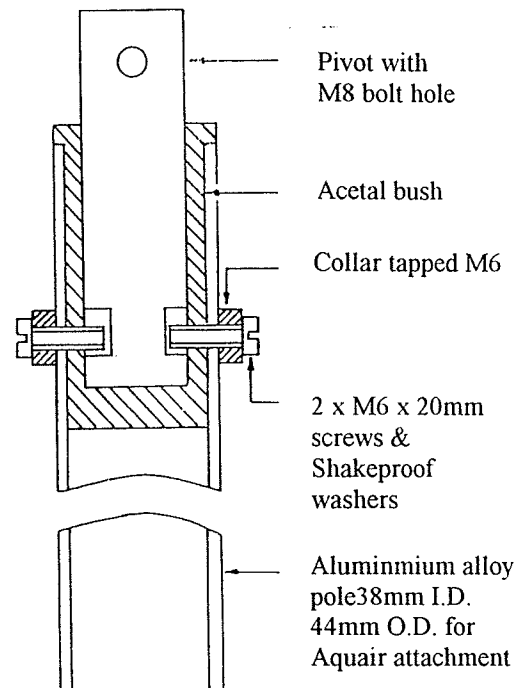

Figure 10. Pole Mount adapter.

CAUTION

LEAVE A FREE LENGTH OF CABLE

This will allow the unit to rotate in the wind.

Do not make the free length so big as to risk fouling the blades.

Final Assembly. Assemble the tail vane and then the wind turbine as above taking particular note of the **DANGER WARNING** regarding personal injury.

DANGER WARNING

The wind turbine blades are easily capable of causing grave personal injury, even in light wind, and should be treated with the same respect as an aircraft propeller.

IT IS ESSENTIAL THAT THE AQUAIR IS MOUNTED WELL ABOVE HEAD HEIGHT

Do not let go of the blades until all personnel are clear. Rotate the Aquair to face the wind and step back before letting go.

STERN MOUNT KIT

The Aquair Pole Mount Generator can be mounted on the stern mount kit of the Ampair 100 Wind Generator.

Pre. Installation Check. Check that a complete and undamaged set of parts has been received.

The Stern Mount Kit consists of one pole type A (four holes either end and two in the middle). One pole type B (as pole A but without the holes in the middle). Two 3mm x 19 stainless steel wire assemblies 2.2m long with thimbles and "D" rings. Two joiner tubes. One yoke. One strut and clamp shell. One pair of angled feet. The hardware kits contain:-

Kit 1. strut & feet fixings

1 M6 x 40mm screw
2 M6 x 35 hex screw
3 M6 shakeproof washers
3 M6 Nyloc nuts
1 M10 screwed rod 75mm
2 M10 shakeproof washers
1 M8 x 60mm hex bolt
2 M8 plain washers
1 M8 Nyloc nut

Kit 2. joiner tube fixings

16 M6 x 10mm screws
16 M6 shakeproof washers

This arrangement places the blade tips 2.2 metres (7 feet 2 inches) above the base fixing. If there is a raised area adjacent upon which people may stand, raise this base accordingly.

Pole position. The pole base fixing may be moved to one side provided that, when viewed from above, the angle between the strut and either wire is greater than 45 degrees.

Pole assembly. Using the joiner tubes and M6 x 10mm screws and shakeproof washers, assemble the poles so that pole A (holes in the middle) is the top pole, pole B (no hole in the middle) is the middle pole and the windkit pole become the bottom pole (two holes only one end for fixing the feet).

Feet. Using the M8 x 60mm bolt washers and nut, fix the feet to the pole end and screw down the feet. The feet should be arranged so the pole can pivot in line with the strut. This usually means aligned fore and aft unless the pole is off-centre.

Backstay strut. Having assembled the poles with joiner tubes site the pole and attach the two "stay" wires with the yoke in place on the pole. File the groove in the strut pole end and clamp shell to accommodate the backstay wire diameter less half a mm. Cut the strut pole to length required. Drill the hole for the strut to yoke bolt in situ to ensure correct orientation of holes.

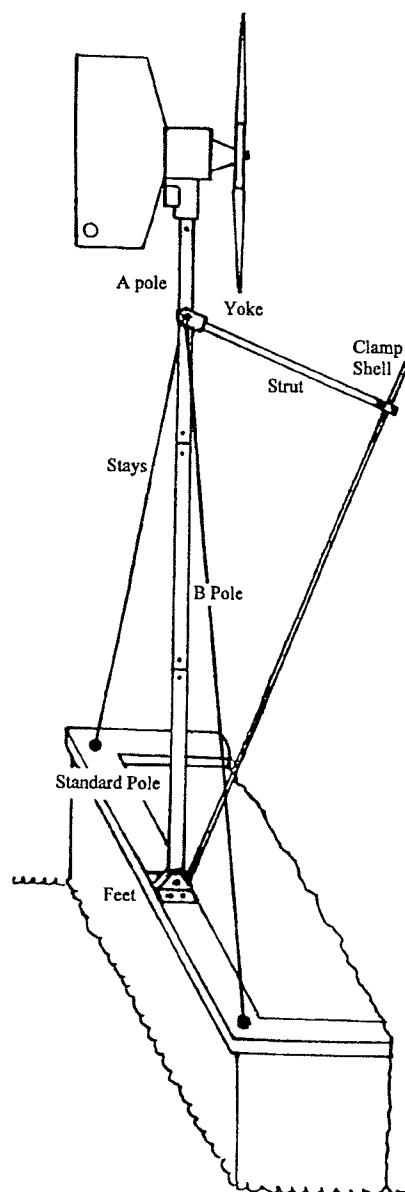

Figure 11. Stern Mount Kit.

ELECTRICAL INSTALLATION

Cables. The Aquair 100 is fitted with 5m of 1.5sq mm cable. Having sited the Aquair 100 on the boat, measure the cable run distance to the batteries. If this distance is less than 10 metres (20 metres 24V systems), use 1.5sq mm (16 AWG) cable. If less than 20 metres (40 metres 24V systems), use 2.5sq mm (14 AWG) cable. Use a similar type of cable to that on the Aquair. Always use tinned stranded conductors.

Connectors. To carry power from the Aquair to the wiring on the boat we recommend that a quality watertight connector be fitted. In the case of a wind and water combination, a watertight socket can be fitted at each site. The sockets should have a watertight cap when not in use.

Installation. Wiring between the deck socket (or junction box, deck gland etc.) and the battery area should be clipped at regular intervals to the structure for safety and a neat job.

Protecting the System. The simplest possible arrangement feeds the power from the Aquair directly to the battery, through an in-line fuse rated at 10 Amps (5 Amps 24V system) in the positive line next to the battery.

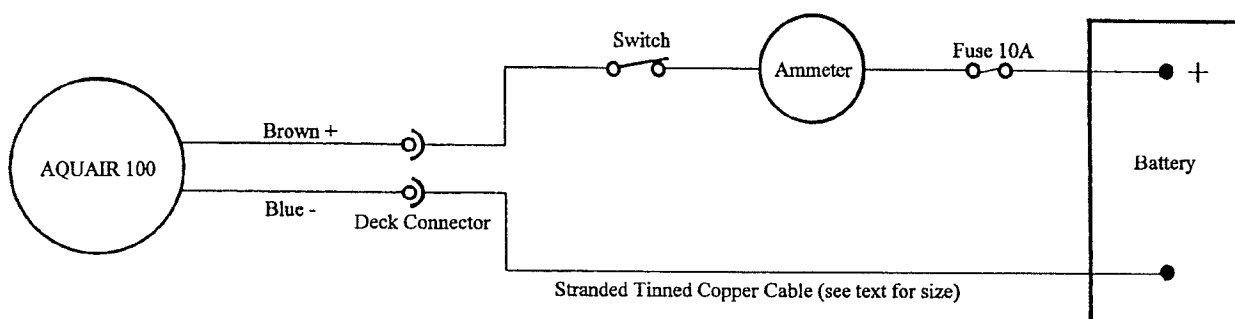

Figure 12. Basic Wiring.

Wiring Options. In Fig 12. two optional components have been added to show where they might be wired in the circuit. The switch, which may be used as a simple means of charge control, should be rated at 15 Amps to ensure long life. The Ammeter is wired in series (assuming it to be of the internal shunt variety) with one line. This will allow the machine output to be seen at all times. As shown, the positive (+) connection of the ammeter is made to the generator, whilst the negative (-) is made to the battery.

Never connect an ammeter across the supply

CAUTION

IT IS MOST IMPORTANT TO FIT A FUSE

The fuse should be next to the battery terminal since, in the event of a fault or damage to the cable, the battery will supply the fault-current.

CAUTION

When wiring the system be aware that if the Aquair is connected to the battery **REVERSE POLARITY** the output rectifiers will be destroyed.

Check and double-check polarity before final connection.

CABLE COLOURS:- BROWN = + Positive : BLUE = - Negative.

CAUTION

THE AQUAIR OUTPUT MUST GO STRAIGHT TO THE BATTERIES.

If the Aquair is connected on the **DOWNSTREAM** (loads side) of the battery isolator switch, it leaves scope for damage to electrical equipment on the boat. Under these conditions it is possible to run the Aquair whilst the battery is isolated. This can subject the system to excess voltage.

AMPAIR manufactures 3 Charge Control Regulators for protecting lead acid batteries from overcharge.

They are not "shunt" type regulators, which dissipate excess charge as heat, but an electronic power switch which disconnects the generator from the battery at the regulation voltage.

Regulators S-M1B & S-M3B have a single 100 watt input (Ampair, Aquair or Solar) and 2 level sensing. The lower voltage (Lo) connection regulates at 0.4 Volts below the high (Hi) connection for 12V systems (0.8V for 24V systems).

"Hi" connection is appropriate for liquid electrolyte batteries and/or live aboard situations, "Lo" connection for gel batteries and/or infrequent use.

The battery voltage is sensed at the regulator output connection, therefore install the regulator as near the battery as practicable and keep the connecting cables short.

Regulator type S-M1B has one output battery connection. Regulator S-M3B has three output connections to serve up to three battery banks. The third Regulator D-M1B has two 100Watt inputs (any two from Ampair, Aquair or Solar), supplying a single battery bank at a fixed regulation voltage.

All regulators feature the same multi-stage regulation programme which has regulation voltages of Lo = 13.6V, Hi = 14.0V for 12V systems (27.2V & 28.0V for 24V systems).

Charging is continuous until the Lo or Hi voltage is reached, depending on the battery output used. The generator is now disconnected from the battery. Off-charge, the battery voltage will fall. At a voltage of 0.5V below the regulation voltage a 30-second time delay is activated.

This delay prevents the regulator from oscillation (hunting) when charging batteries under load. After 30 seconds has elapsed, the generator/battery connection is remade and charging continues to the regulation cut-out voltage.

A cycle counter counts the charge/disconnect cycles and at the tenth cycle increases the regulation voltage for one cycle only by 0.4 volt to Lo = 14.0V or Hi = 14.4V for 12V systems (0.8V for 24V systems Lo = 28.0V, Hi = 28.8V).

This provides an equalisation charge for the battery. Subsequent cycles return to the lower settings until a further 9 cycles are completed.

Ammeter:

We recommend fitting an ammeter (see price list) to monitor charging. Fuses: Battery protection fuses should be fitted. Use 10Amp values in 12 volt systems, 5Amp for 24volts.

Wiring: Use suitably insulated cable of 1.5 sq. mm (16 A.W.G.) between regulator and battery, for single source systems, 2.5 sq. mm (14 A.W.G.) for dual source.

For wiring to the regulator see appropriate generator wiring section.

The use of Screened Cables is recommended if the cables run close to equipment radiating strong electrical fields e.g. Radio transmitters or Aerials.

INSTALLATION

At initial start-up, allow a gap of 1 min. for circuit timing functions to become active.

CHARGE CONTROL Protecting the system.

Fuse Warning - Never omit fuses, simple in-line fuse carriers may be used, they protect your system from excessive battery currents in the event of a serious electrical fault. If they keep blowing, find out why.

Fuses = 10A - 12V systems : 5A - 24V systems.

All multistage regulators are internally protected by an SAE cartridge fuse.

These are not substitutes for battery protection fuses.

The fuses must be next to the battery terminals since, in the event of a fault, the batteries would source the fault current. Check and double-check polarities before making connections, insert the fuses in the fuse carriers last of all.

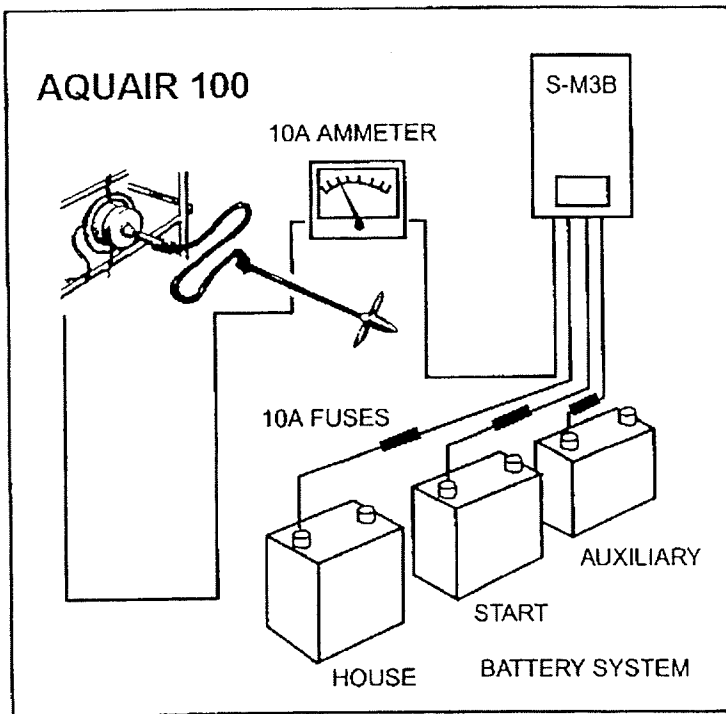
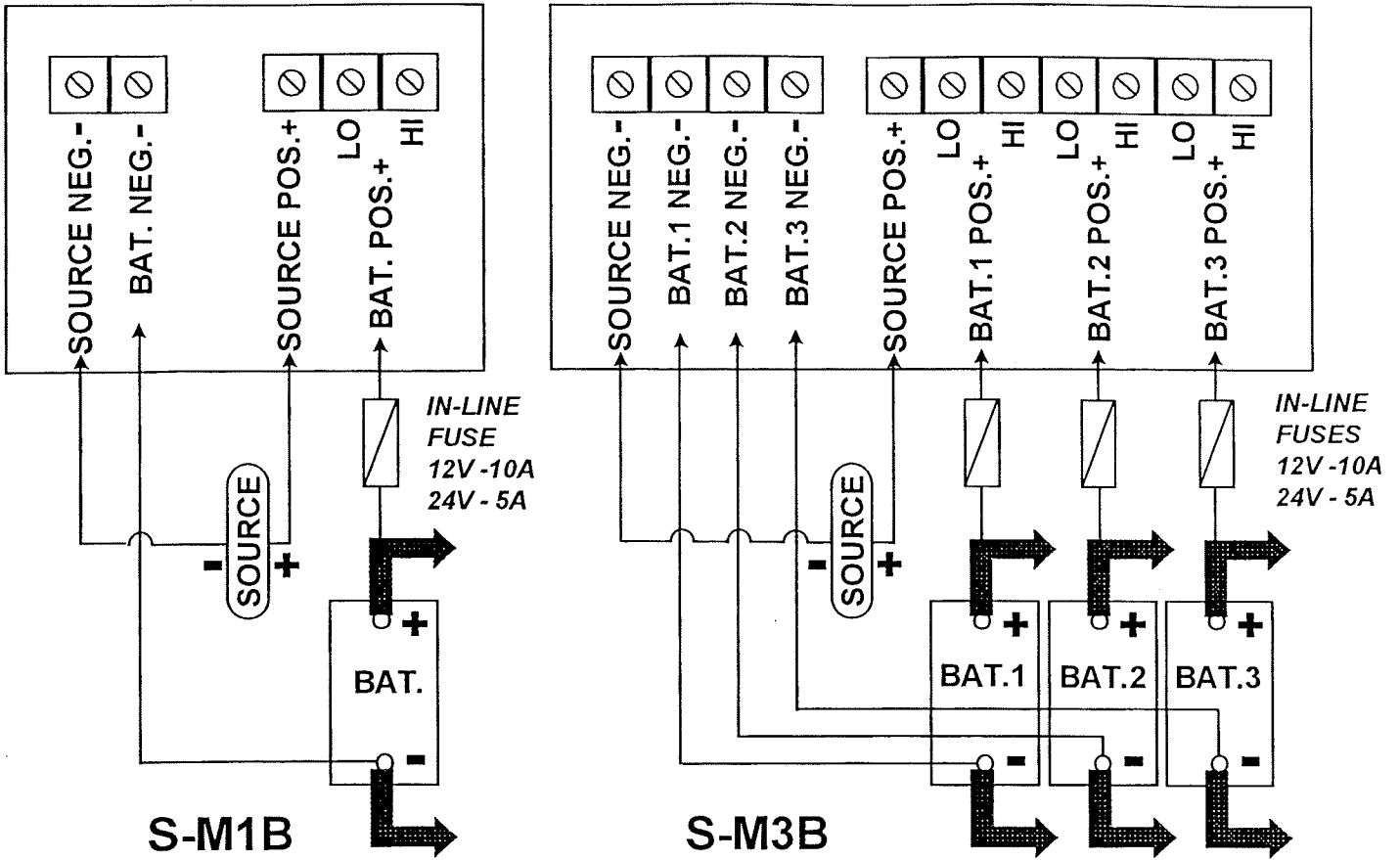

12V System showing 3 batteries installed with an AMPAIR S-M3B Charge Control Regulator

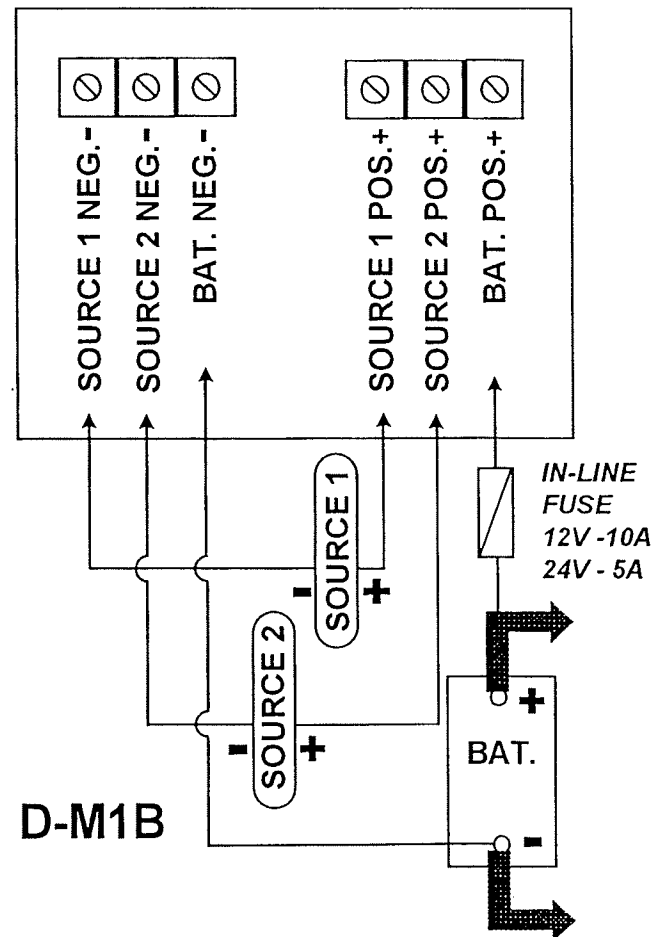

Figure 13. Charge Control Regulators

Corrosion - This is the enemy of all electrical connections, especially in marine environments. Site regulators in a weather proof location, as dry as possible and splash proof. Inspect all terminations and connections for signs of corrosion. Rectify by cleaning, remaking etc. Use tinned copper wire for extension leads to prevent corrosion spreading inside cable insulation.

Operating Problems - A digital multimeter is useful for checking operation/fault finding if no permanent monitoring instruments are used. Battery voltage levels and those of the charging source can be read directly. Charging current readings will require the multimeter to be installed in line. In this way currents into and out of the regulator can be observed. Do not remove battery connections since regulator operation depends on a very small supply current. If the regulator is suspect then it can be temporarily bypassed by connecting the source positive direct to a battery positive. The negative connections are common and do not need disturbing unless regulator replacement is necessary. Use the multimeter continuity range to confirm all cable runs are low resistance.

Operation. When installed, the generator and regulator will run and maintain the batteries automatically. The unit may be run in conjunction with any other charge-source with no known interactive problems. Regular battery inspection and topping up must still be carried out to obtain maximum battery life.

FAULTY REGULATOR.

If the regulator is suspect, then it can be temporarily bypassed i.e. connect the Ampair directly to the battery terminals observing correct polarity. If this reinstates correct charging, then the regulator must be serviced or replaced. Regulators draw a small current (typically 1mA at 12V) from the battery to activate the sense and control circuits. **Without this connection the regulator will be inoperative.**

OPERATION & PERFORMANCE

WATER MODE

It is assumed that the Aquair has been installed in accordance with the **INSTALLATION** section and that the water turbine and tow rope are firmly attached.

Starting up. Lay the tow rope out on the deck in such a way that it can be payed out without risk of snagging or knotting when the turbine is put in the water. This should be done when the boat is under way. Slight tension should be applied as it runs out to prevent the turbine grounding if in comparatively shallow water. The tow rope should not pass close to steering gear etc. which could cause chafing.

The standard pitch water turbine is likely to surface at speeds in excess of about 7 knots, depending on sea state and the height above the water at which the Aquair is mounted. This can lead to snatching on the rope as the turbine jumps as it breaks surface and the possibility of knotting. Matters can be improved (at the expense of performance at lower speeds due to increased droop) by adding weight to the turbine, eg. stainless steel or brass tubing on the shaft. Some customers have stated that sacrificial zinc anodes, of the type for clamping around a shaft, may be used as weights, both on the turbine and the rope. Other customers have reported the fact that the rope may be shortened particularly in those cases where the Aquair is mounted on a low transom.

Coarse pitch turbine. For boats which can consistently exceed 7 knots, a coarse pitch water turbine is recommended. Due to its reduced drag, it has less tendency to surface. There will, however, be a significant loss of performance at any given speed. See graph of Water Driven Performance. A coarse pitch water turbine has been used successfully at speeds up to 20 knots by increasing the rope diameter to 14mm and shortening it to about 15 metres so as to stay in the same wave as the boat. Coarse pitch turbines have a circumferal groove around the propeller for identification purposes.

Performance. The graphs show the power output obtained and the drag for a range of speeds.

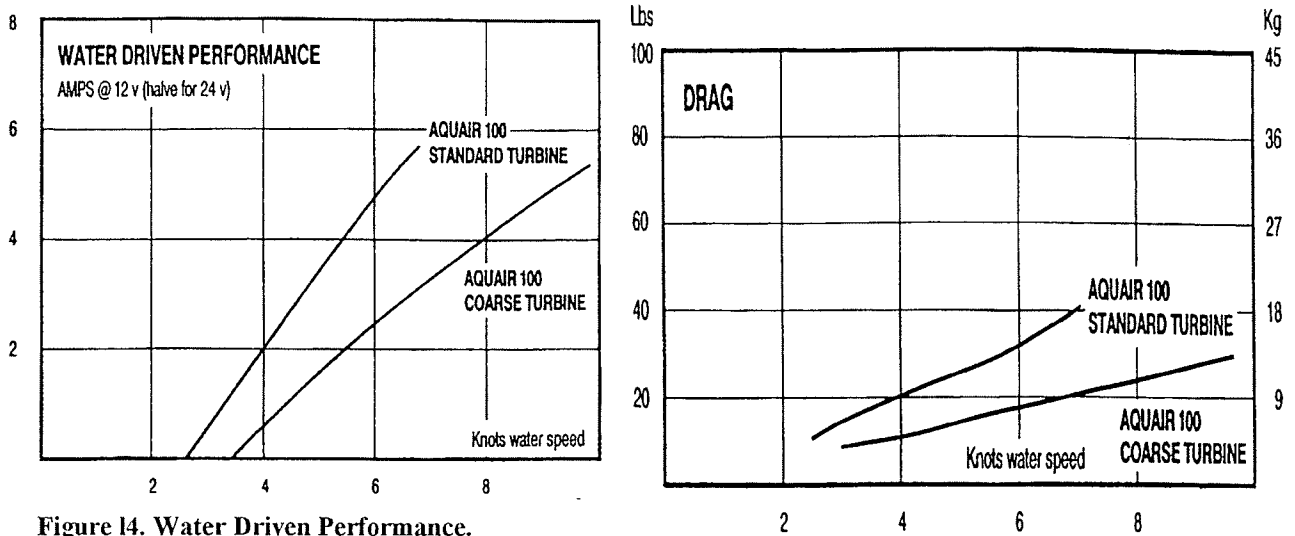

Figure 14. Water Driven Performance.

Hauling in. Since the rope is spinning, to avoid hand injury, the boat should be slowed to 1 - 2 knots when hauling in. A useful device, to help when hauling-in whilst under way, may be made from a large plastic funnel, with most of the spout cut off, slit down the side and fitted with velcro straps. This is slid down the tow rope where it will stop the turbine spinning, allowing easier hauling.

CAUTION:

To avoid personal injury, wear sturdy gloves as a precaution. Reduce speed when hauling-in since the water turbine causes considerable torque.

WIND MODE

Starting up. It is assumed that the Aquair has been assembled and installed in accordance with the section on INSTALLATION. The unit is not designed for permanently unattended operation, it is important to occasionally check to see that the output cable has not trapped round the swivel (or pole) due to wind veer/boat movement.

Performance. The graph shows the power output for a range of wind speeds. The drag due to the wind turbine is about 22kg (50lbs) at 50 knots wind speed.

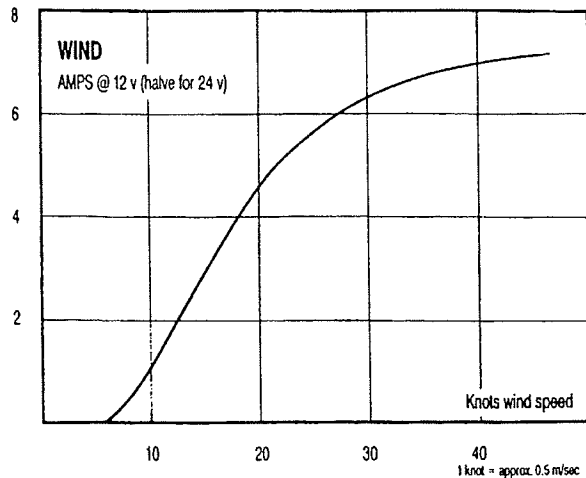

Figure 16. Wind Driven Performance

Stopping. The wind turbine has been designed to survive storms, however, it is a good plan to stop the machine if a gale is expected. To do this, proceed with caution, approach the Aquair from downwind and grasp the tail vane with a boat-hook or similar. Carefully turn the machine off wind and, when the blades stop, throw a rope over them and tie down. If a hurricane is expected take the unit down.

CAUTION

To avoid personal injury wear sturdy gloves as a precaution. The wind turbine blades are capable of causing **GRAVE INJURY** and should be treated with the same respect as an aircraft propeller.

MAINTENANCE AND SPARES

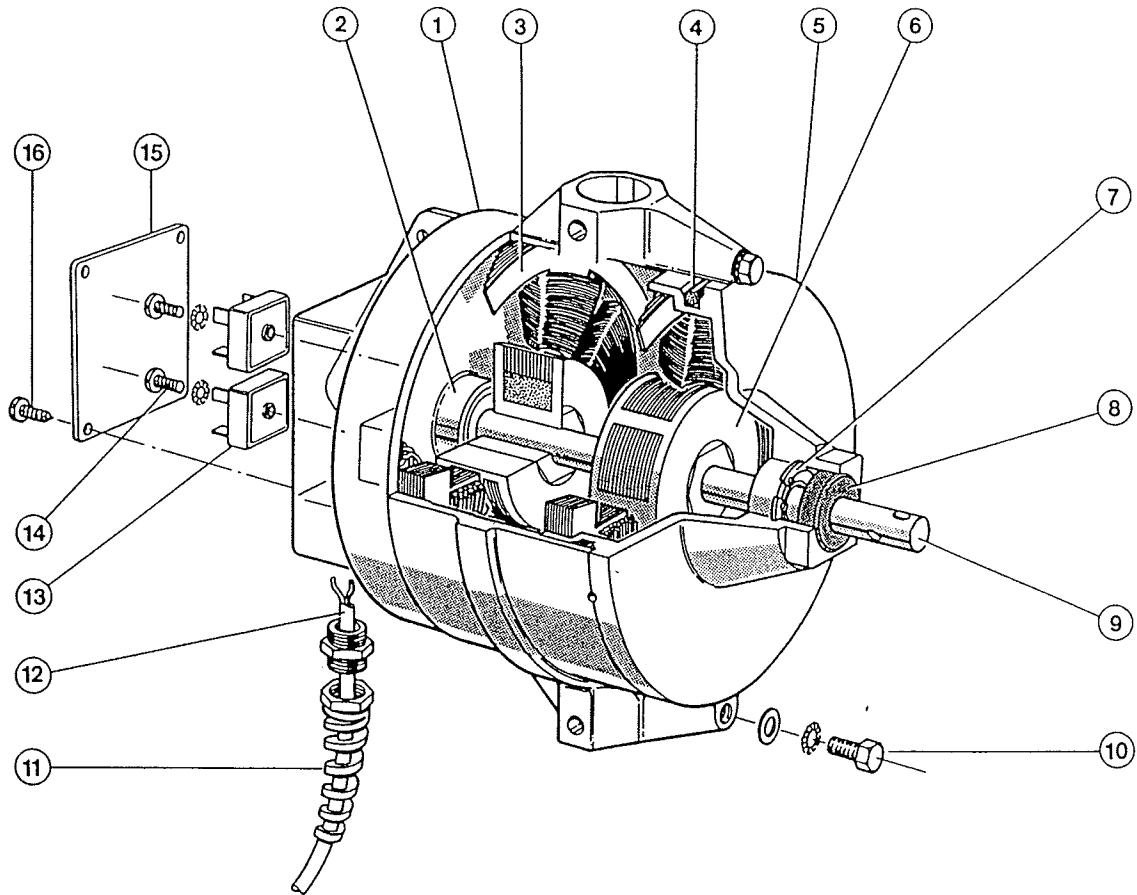

Figure 17. Sectioned Drawing.

KEY

- | | |
|--|---|
| <ul style="list-style-type: none"> 1. After-body 2. Bearing (2): 15 x 35 x 11mm sealed 3. Stator (2) : Six pole. 4. O ring: Intl. size 358 5. Fore-body 6. Rotor (2) Permanent Magnet 7. Internal Circlip: 35 x 1.5mm 8. Shaft seal: 15 x 35 x 7mm rubber coated plain lip | <ul style="list-style-type: none"> 9. Shaft: with two M6 tapped holes 10. Body fasteners (2): M8 x 25mm, Shakeproof, Fibre & Plain washers 11. Cable gland: with tail 12. Output cable: 5m of 1.5sq mm tinned Copper twin, Low temp PVC 13. Rectifiers (2): 25 Amp 600V 14. Rectifier fasteners (2): M5 x 16 pan head, shakeproof washer 15. Rectifier cover: 16. Cover fasteners (4): No 8 x 3/8" self tapping, M4 Fibre washers |
|--|---|

INSPECTION.

The shaft seal protecting the front bearing should be renewed regularly, particularly after long ocean voyages. The bearings should be replaced when they become noisy.

In Water Mode, regularly inspect the following:

- Suspension lanyards
- Shaft connector & shackle
- Tow rope attachments
- Gimbal Pivot components

Inspect the body and tow turbine occasionally, cleaning off any corrosion and re-painting any damaged areas. The shaft connector has a second set of holes which can be used once the original holes show signs of wear or elongation.

If the tow turbine blade tip become bent as shown in Fig. 18, this will cause a change in pitch, increased drag and premature surfacing. View the trailing edge of the blade, edge on, as shown. The edge should appear as a straight line with the pitch angle at 15 degrees close to the tip (standard pitch turbine) . If this is bent, tap the tip back into shape using a support block as shown.

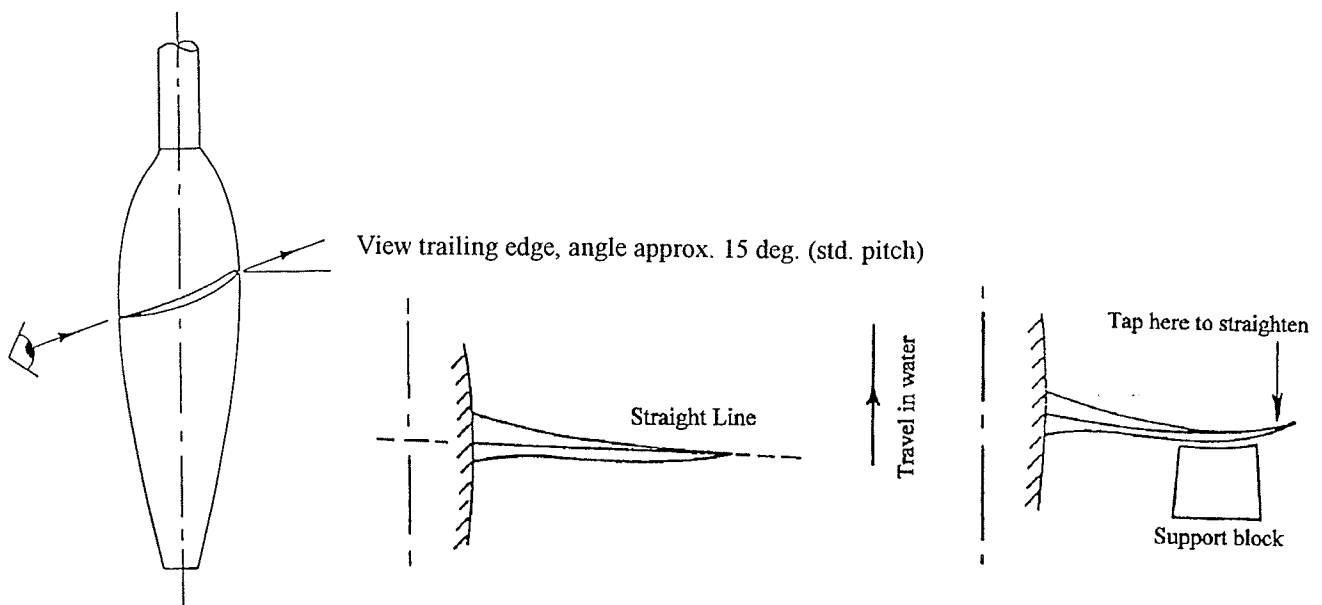

Figure 18. Water Turbine Maintenance.

In wind mode, regularly inspect the following:- Hub to shaft screws (Priority No. 1) - Blade bolts & nuts
Hub-centre screws - Wind turbine blades - Tail vane screws - Swivel pole (or Pole mount) bolts

Inspect the machine after stormy weather for signs of accidental damage. Any minor nicks in the edge of a blade may be dressed out but the blade must be replaced if there is any sign of damage or cracking near the root. Since the blades are supplied as matched, balanced pairs, any damaged blade must be replaced along with its opposite number. The unit may be run with two blades missing (whilst the replacements are obtained) at reduced performance since difficulty in starting will be encountered.

NEVER ALLOW THE MACHINE TO RUN OUT OF BALANCE

The blade material has exceptional fatigue resistance which is of the utmost importance in hostile locations such as tropical sunshine and mountain tops. The material is, however, subject to slow degradation due to ultra violet light which increases towards the tropics and with altitude. The deterioration is slow and when it become apparent as a white powderiness of the blade surface, particularly along leading and trailing edges, the blades may be carefully painted with two-pack polyurethane after a light sanding.

DO NOT MIX UP THE BALANCED PAIRS !

MAJOR DISASSEMBLY.

Should the generator have to be taken apart for any reason, some force may have to be used to break the "Loctite" bearing joints and O ring. If difficulty is experienced, a puller may have to be improvised. Referring to the drawing, remove the fore-body carefully as it cannot be withdrawn far due to the front stator wiring connection. This job should, therefore, be done on a suitable work bench. The rear bearing needs a bearing puller to remove it, if no puller is available, a dummy shaft may be fixed in the bearing centre using epoxy adhesive and, when cured, the bearing worked loose. The front bearing may be drifted out following removal of the seal and circlip.

Prior to re-assembly, the bearing housings, the bearings inner and outer surfaces and the shaft surfaces should all be thoroughly cleaned and degreased.

When reassembling use adhesives as follows:-	Stator to body -	Loctite 648
	Bearings to body -	Loctite 641
	Shaft to bearings -	Loctite 641

When replacing the fore-body, make sure that the O ring is in place and well smeared with silicone grease. Assemble the body checking that the wiring to the front stator cannot touch the rotor. Ensure that the timing marks on the body junction line coincide. If the "cogging" or break-out torque has been correctly minimised, 12 minor, equal "lumps" of resistance per revolution will be felt when turning the shaft by hand. This resistance should not exceed 2kg-cm (3Ooz-in). When doing this make sure that the output leads are not shorted together.

RECTIFIERS

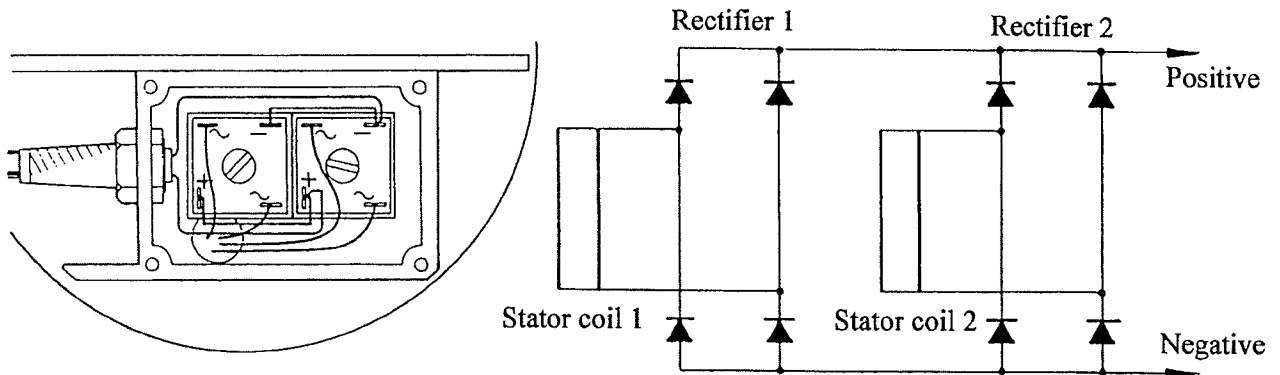

Figure 19. Aquair 100 Internal Wiring Diagram.

The rectifiers are located in the small box on the back of the Aquair body. To inspect them, remove the four screws and the plate. This has been sealed with polyurethane sealant. The sealant must be renewed on re-assembly after the mating faces have been cleaned. Damp, salt laden air will be sucked inside the generator if the seal is not effective.

A simple method of checking the machine's output is to disconnect it from the battery and short together its output leads whilst turning the shaft by hand. A marked increase in resistance to turning should be felt as the shorting takes place.

Possible faults to consider if reduced output is suspected:-

Poor or corroded wiring connections. Inspect all the screw terminals in the Aquair circuit for signs of fatigue or corrosion. (The commonest cause of reduced output is corroded wiring between generator & battery)

Faulty stator. Check A C input to rectifiers or check for coil continuity and isolation from the case. The resistance should be less than two Ohms (approx. three Ohms 24V units). Stator replacement involves baking in an oven to break the adhesive bond and is best undertaken at the factory.

Faulty Rectifiers. Unsolder the commoning links between the rectifier outputs and check outputs separately. If a new rectifier has to be fitted, scrape the enamel off the stator wires before soldering and sleeving.

Diode Test. This test will show if the rectifier diodes are either open or short circuit. If your multimeter has a diode check feature, select this (if not select the highest resistance range) and apply the red meter lead to the positive, black lead to negative, and note the reading. Now reverse the connections.

METER LEAD POSITION	MULTIMETER SETTING	
Red to Positive	DIODE TEST No Reading	or Many Megohms* = O K
	Reading	or Low resistance = U S
Black to Positive	1.2V (2 diode drops)	or Markedly less* = O K
	No Reading	or High resistance = U S

*This test is not as conclusive as the Diode Test method however, provided the first reading is a very high resistance and the second reading far lower, then the test is valid. Actual values will depend on the voltage supplied by the particular meter for its resistance ranges.

RECOMMENDED SPARES.

For ocean passages a spare water turbine and shaft connector are recommended. When speeds of over 7 knots are frequently encountered a coarse pitch turbine should be chosen as the spare to allow a choice.

To cater for accidental damage in the wind driven mode, it is suggested that a spare pair of blades be carried. Other spares worth considering are:-

2 bearings	Unlikely to be required but an insurance policy
2 rectifiers	Unlikely to be required unless polarity is accidentally reversed , however, another insurance policy.
Shaft seal	Regular replacement required, dependant on use.
Pivot pin & Bush set	To cater for accidental loss when changing modes.
Shaft Connector	To cater for wear or over strain.

DIMENSIONS.

Aquair Body.

Shaft diameter	15mm
Gimbal ring diameter	280mm (11")
Body diameter (over pivot ears)	220mm (8.66")
Body diameter	175mm (6.89")
Body length (including shaft connector)	340mm (13.4")
Body length	310mm (12.2")
Generator and gimbal weight	9kg (21 lb.)

Water Turbine and Rope.

Turbine length	770mm (30")
Turbine diameter	280mm (11")
Turbine weight	3kg (7 lb.)
Tow rope diameter	12mm (.5")
Tow rope length	30m (100')
Rope weight	3kg (7 lb)

Wind Mode Hoist in Rigging.

Swivel pole height over all	1140mm (45")
Swivel pole outside diameter	29mm (1.13")
Turning Radius	480mm (19")
Wind turbine blade diameter	915mm (36")
Suspended weight	13kg (28 lb)

Wind Mode Pole Mount.

Mounting pole length	800mm (31.5")
Mounting pole outside diameter	44mm (1.75")
Mounting pole inside diameter	38mm (1.5")
Turning radius	480mm (19")
Mounted weight including pole	13kg (28 lb)

Ampair

Park Farm, Warfield, Berkshire RG42 5RH, UK

Tel: +44 (0)845 389 0660 Fax: +44 (0)1344 303 312

service@ampair.com www.ampair.com

© Copyright Ampair 1998